

SERIES 68P

Long Life Potentiometer Substitute

FEATURES

- Ratiometric analog output
- Debris resistant Hall effect sensor technology
- 3 million rotational cycles
- Redundant output
- Custom output options
- Optional shaft and panel seal
- Reverse voltage and overvoltage protection

APPLICATIONS

- Test & Measurement equipment
- Audio / Visual equipment
- Potentiometer substitute with long life
- Agriculture & Construction engine speed control

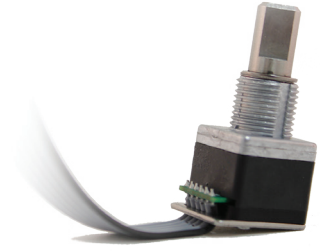

DIMENSIONS in inches [millimeters]

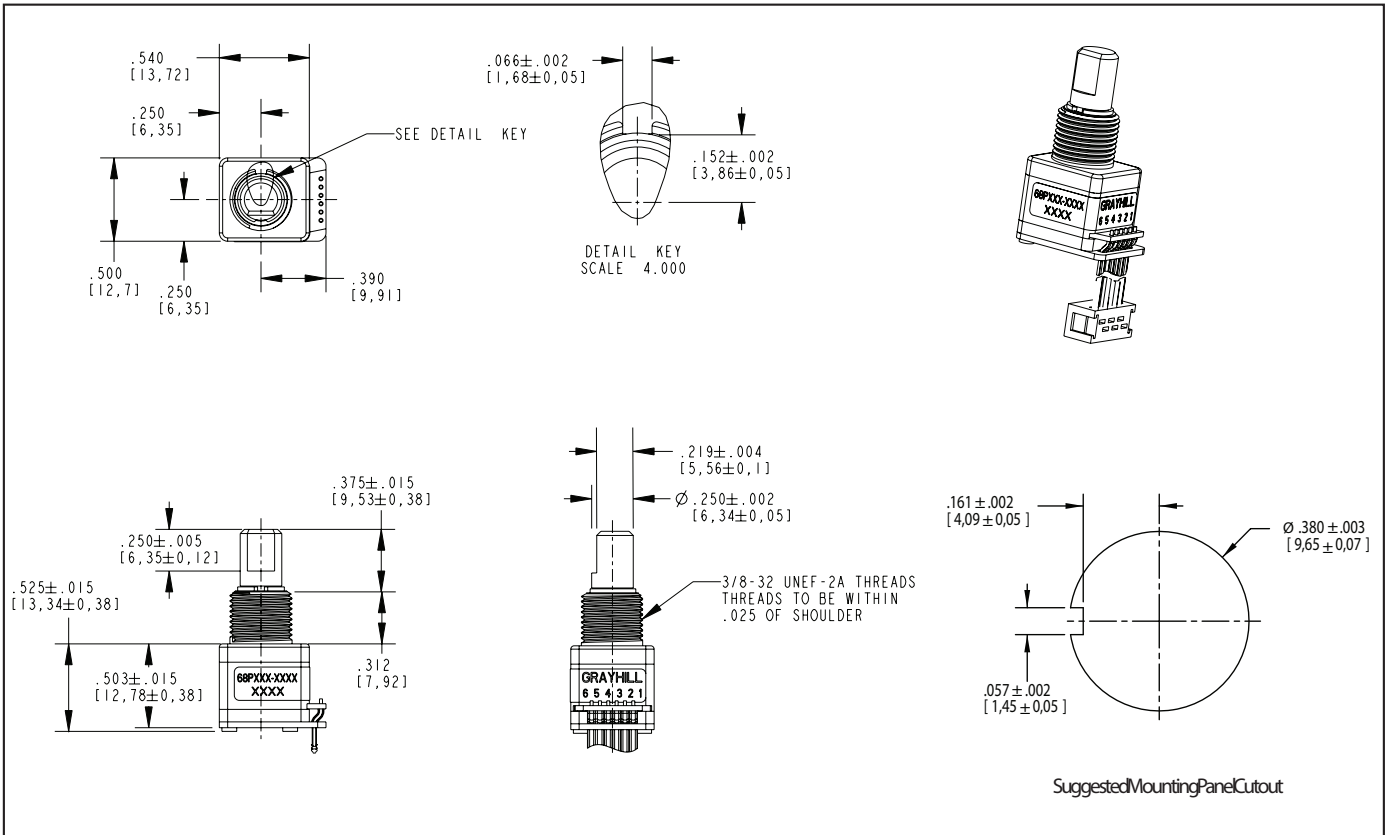

Hall Effect

TERMINATION OPTIONS

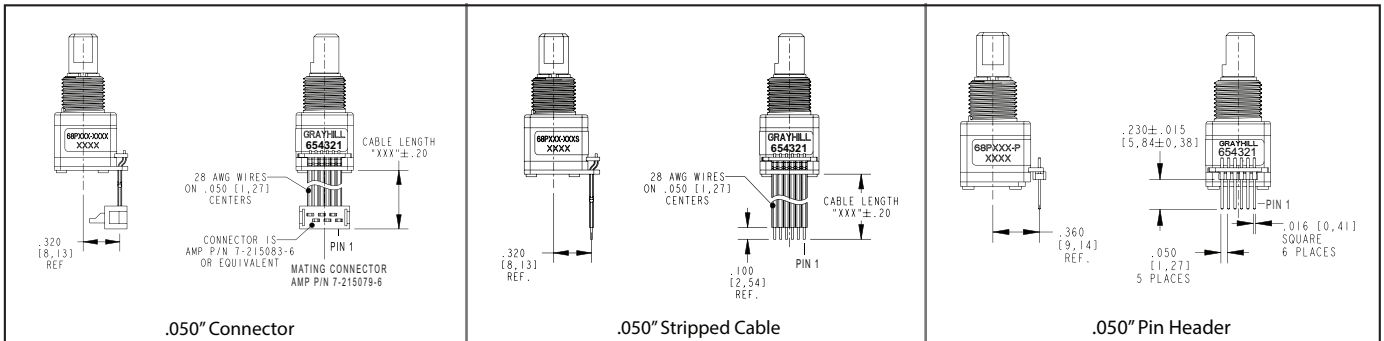

ELECTRICAL SCHEMATIC

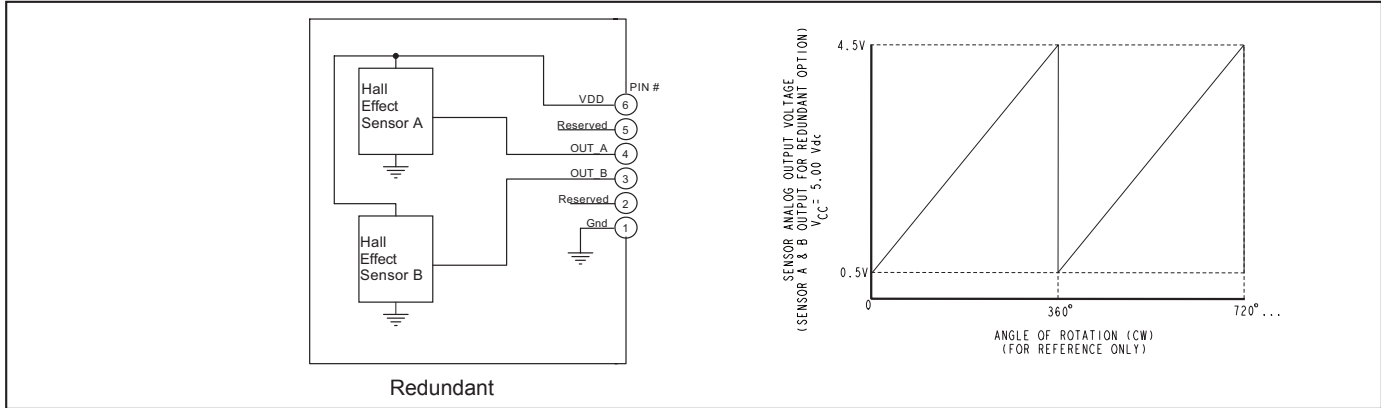

* Customized electrical outputs are available. Contact Grayhill for additional details.

SPECIFICATIONS

Electrical Ratings

Operating Voltage: Minimum 4.5V, maximum 5.5V (VDD)
Absolute Maximum Voltage* on Pin 6 (VDD): -18V to +27V
Supply Current Redundant Sensors: Typical 22mA, maximum 40mA
Output Current: 2.5mA max
Recommended Load: 2K-5.6K Ohms Pull-Down Resistor
Power-Up Time: 20ms
Sensor Error: When an internal sensor error occurs, the output goes to $\leq 4\%$ of supply (VDD)

Solderability: 95% free of pin holes & voids, MIL-STD-202, Method 208

Environmental Ratings

Operating Temperature: -40°C to 85°C, IEC 68-2-1, Test Aa and IEC 68-2-2, Test Aa
Storage Temperature: -55°C to 85°C, IEC 68-2-1, Method Aa and IEC 68-2-2, Method Ba
Humidity: 96 hours @ 90-95% humidity @ 40°C, MIL-STD-202, Method 103B
Mechanical Vibration: Harmonic motion with amplitude of 15g within a varied frequency of 10 to 2000 Hz for 12 hours, MIL-STD-202, Method 204, Test Condition B
Mechanical Shock:
 Test 1: 100g for 6 ms half-sine wave with a velocity change of 12.3 ft/s.
 Test 2: 100g for 6 ms sawtooth wave with a velocity change of 9.7 ft/s, MIL-STD-202, Method 213, Test Condition C and I
Thermal Shock: 25 cycles from -55°C to 100°C, MIL-STD-810F, Method 503.4, procedure I
Seal: IP67, Meets IEC 60529

Cable: Copper stranded with topcoat in PVC, 28 AWG (cable version only)
Header Pins: Tin-plated phosphor bronze
ROHS Compliant

EMC Ratings

Radiated Immunity: Meets ANSI/ASAE EP455 5.16 (100 V/m, 0.014-1000 MHz, 3 orientations)
Conducted Immunity: Meets IEC 61000-4-6, Level 3
Radiated Emissions: Meets ISO 14982, Sec 6.4 (Broadband), Sec 6.5 (Narrowband) limits
Conducted Emissions: Meets CISPR 25, Class 3
Electrostatic Discharge: Meets ANSI/ASAE EP455 5.12, Level 1
Power Frequency Magnetic Field: Meets IEC 61000-4-8, 100 V/m

* Exceeding the Absolute Maximum Voltage may result in permanent damage to the device. This is a stress rating only and functional operation of the device at those or any other conditions above those indicated in the operation listings of this specification is not implied.

Soldering Recommendation

Hand solder only per IPC J-STD-001

Physical & Mechanical Ratings Mechanical

Life: 3,000,000 cycles of operation. 1 cycle is a rotation through all positions and a full return
Average Rotational Torque: 1.5 in-oz maximum
Maximum rotational speed: 100 rpm
Mounting Torque: 15 in-lbs. maximum
Shaft Pushout / Pullout Force: 45 lbs. / 45 lbs. minimum
Terminal Strength: 15 lbs. minimum. Cable Or Header pullout force, MIL-STD-202, Method 211A, Test Condition A

Materials and Finishes

Bushing: Zinc
Shaft: Stainless Steel
Hex Nut: Nickel plated brass
Lockwasher: Spring steel, zinc plate with clear trivalent chromate finish

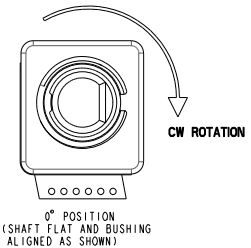

Encoder has ratiometric analog output (output levels are proportional to the supply voltage). Specifications on this datasheet apply @ VDD = 5.00 V.

ORDERING INFORMATION

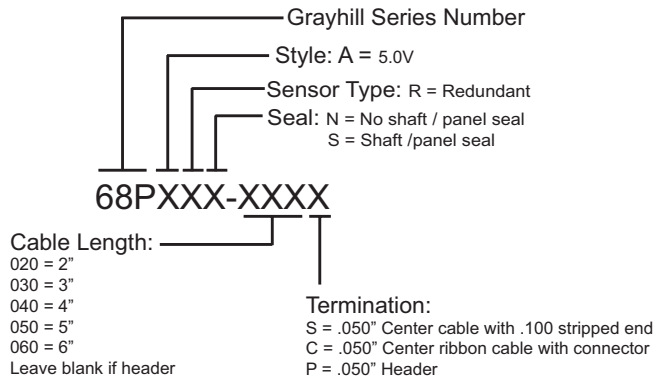

MOUNTING PANEL RECOMMENDATIONS FOR PANEL SEAL VERSION:

1. Panel thickness should not exceed 0.157".
2. Mounting hole diameter to be per recommended dimensions.
3. 0.470" X 0.020" counter bore required for proper sealing.
4. Anti-rotation feature is recommended. Feature should be designed to lock into bushing keyway.

For prices and custom configurations, contact a local sales office, an authorized distributor, or Grayhill's sales department.